

Determination of Rock Mass Properties by *In Situ* tests In the Gilboa Pumped Storage Project

Levin, M.^{a*}

^a*Geotope geo-engineering monitoring Ltd. Hararit, Israel*

* mlevin@geotope.co.il

Abstract

The geotechnical study of the Gilboa Pumped Storage Project adopted a new *in situ* testing approach which involved combining the Plate Loading Test (PLT) and a series of Flat Jack Tests (FJT) in order to determine the rock mass properties and the in-situ stress conditions. The *in situ* tests were used to verify the design base parameters of the rock mass, which were calculated during the preliminary design stage by reduction of intact rock properties based on the GSI method.

The Gilboa Pump Storage Project (2 X 150MW) will supply 300MW of peak power to the Israel Electric Corporation (IEC). The project will include two pump-turbines that are able to convert hydraulic energy into mechanical energy and vice-versa. The project will also involve the construction of 4.5km of tunnels, two large underground caverns for the powerhouse, and a vertical shaft of 500 m depth. The geotechnical site investigation included deep core drilling to a depth of 570 meters.

The project is located in Israel and is situated 6 km west of the Jordan Rift Valley, which is an active tectonic boundary between the Arabian plate and the Sinai plate.

The rock mass properties were obtained via in-situ testing. This allowed for optimal design of the steel pipe and concrete lining along the high pressure tunnel and for the support design of the two large turbine caverns. The PLT was conducted using a hydraulic jack, which was installed in a test adit in order to measure the horizontal and vertical deformation modulus, whereas the FJT involved the installation of six flat jacks on different angles relative to the tunnel axis. The evaluation of both the values and orientation of the principle stresses will involve the development of an analytical solution for the FJT. This will occur during the next stage of the collaborative study between the Rock Mechanics research team at Ben-Gurion University and GEOTOPE Geo-engineering Monitoring Ltd.

Keywords: Gilboa, Pumped Storage, Deformation Modulus, Plate Loading, Flat Jack

1. Introduction

Valid and realistic prediction of rock mass properties is a challenging task for the engineering geologist in any rock engineering project. Common methods of geotechnical site investigation combine several approaches for measuring the rock mass properties; these may include core drilling, laboratory tests, *in-situ* tests in boreholes and geophysical methods. The final evaluation of the rock mass properties during the design stage is therefore like piecing together a puzzle; it requires the construction of a clear image comprised of many sources of information, all of which have different levels of reliability and accuracy. One of the greatest challenges for engineering geologists and tunnel engineers is to predict the deformability modulus of the rock mass and the *in-situ* stress conditions at depth. In the first stage of the design, the engineering geologist must acquire a detailed geological history of the region. Understanding the structure and setting of the geological formations allows for optimal execution of the geotechnical site investigation. However, even if an optimal site investigation has been conducted and a good correlation between all the rock mass parameters has been established, data cannot be collected on the actual rock mass behavior until the construction stage begins. Therefore, various open issues may be present in the design. These issues are generally resolved only after a certain point in the project that depends on the rate of advance of the excavation, the level of complexity of the project, and the time required ordering essential parts from different manufacturers.

The Gilboa mountain range extends from southeast to northwest from the highlands of the West Bank on the south to the Beit She'an and Jizrael valleys on the east and north. The project is located 6km west of the Jordan Rift Valley, which is an active tectonic boundary between the Arabian plate and the Sinai plate. The project is located in close proximity to the Gefet fault which splays from the Carmel – Gilboa fault (see Figure 1).

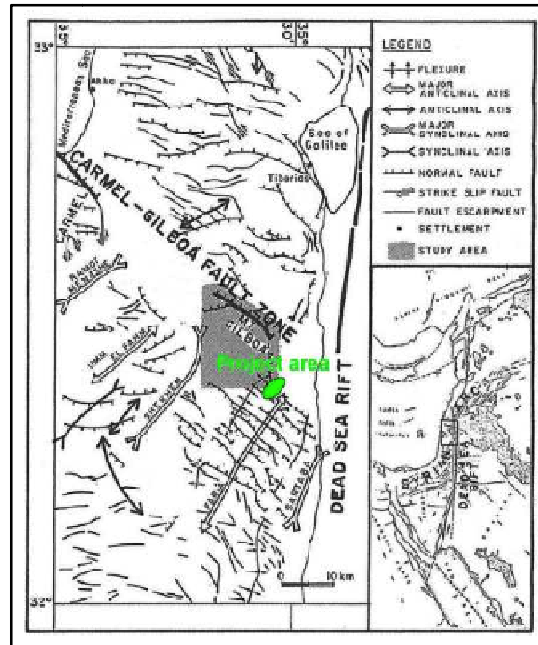

Fig. 1: Tectonic setting of the Gilboa region(Hatzor and Reches, 1990)

The Gilboa Pumped Storage Project (P.S.P) is designed to be a 300MW electrical hydro-power plant. The project includes the construction of 4.5km of tunnels, two large underground caverns for the powerhouse, and a vertical shaft of 500m depth. The water supply to the plant will include the primary supply of water from an adjacent well to be stored in two large reservoirs with a full capacity of approximately 2.5 million cubic meters each. The altitude of the Gilboa ridge reaches a height of 508m/1,667ft above sea level, with a summit at 628m/2,060ft above the town of Bet She'an, which lies 120m/393ft below sea level. As the Gilboa ridge is an agricultural region, the upper reservoir will be built on an agricultural plot of land, and the lower reservoir will be constructed near existing water reservoirs (Figure 2).

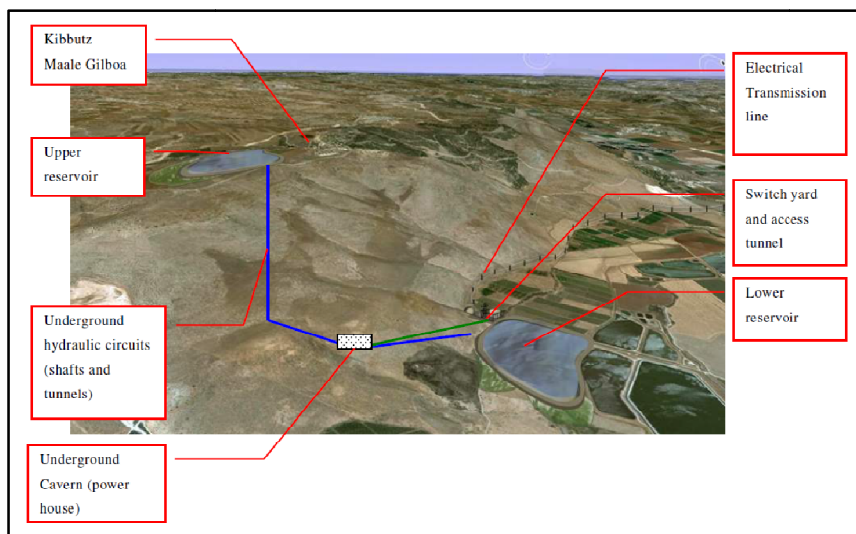

Fig. 2: A general view of the Gilboa Pumped Storage site

The geotechnical site investigation of the Gilboa P.S.P. was limited by the number of boreholes permitted due to the fact that the project is situated beneath a national park, and thus, Israeli regulation does not allow drilling along the mountain's slopes. As a result, only two deep boreholes and two shallow boreholes were performed along the underground section (GHPS-1, located at the vertical shaft; GUPH-1, located close to the underground powerhouse; and GOPH-1 and GOPH-2, located at the bottom of the slope near the Gefet fault). The boreholes were logged according to ISRM suggested method for quantitative description of soil and rock. Further analyses of the structural and discontinuity characteristics of the rock mass were performed using down hole image oriented photography with a BHTV, and the interpretation was executed using the WellCAD[®] software. *In-situ* tests including Lugeon tests and hydro-jacking tests were utilized in order to characterize the hydraulic parameters of the rock mass. Seismic velocities, V_p and V_s , were logged using an OYO suspended P-S logger. The interpretation of all the geological and geotechnical data was presented in a simplified geotechnical cross section (Figure 3).

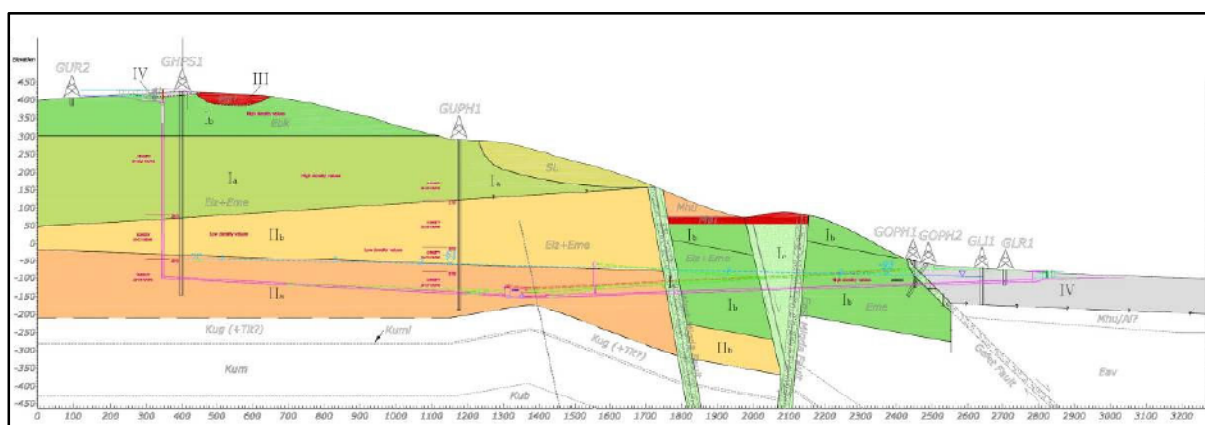

Fig. 3: A simplified geotechnical cross section of the Gilboa P.S.P

Based on the density of the rock, the shear modulus G , the Poisson ratio ν and the elastic modulus E are calculated from the logged V_s and V_p according to equations (1), (2) and (3).

$$G = \rho V_s^2 \quad (1)$$

$$\nu = \frac{\left(\frac{V_p}{V_s}\right)^2 - 2}{2\left(\frac{V_p}{V_s}\right)^2 - 2} \quad (2)$$

$$E = 2G(1 + \nu) \quad (3)$$

An alternative method for the prediction of the deformation modulus of the rock mass E_{rm} was performed using the GSI method (Hoek E, Brown E.T., 1997), which is a reduction procedure that combines the physical properties of the intact rock, the lithology, the structure of discontinuities and discontinuity characteristics. Nevertheless, it was still imperative to define the exact deformability behavior of the rock, as it was one of the essential parameters affecting the properties of the steel lining and the support of the turbine caverns.

The calculated values of E_{rm} based on the seismic velocities were around 25%-30% of the elastic modulus of the intact rock E_i , which was determined based on laboratory tests performed on solid cylinders of intact rock samples.

The calculated values of E_{rm} based on the GSI method were around 50% of the average elastic modulus of the intact rock E_i .

2. Physical properties of the intact rock

The interpretation of the laboratory results shown in Figure 4 separate the rock mass into five geotechnical units based on the ratio between Uniaxial Compression Strength (UCS) versus the Dry Density. Similar interpretation of elastic moduli from the deep borehole GHPS-1 is shown in Figure 5 indicating decrease in the E values due to the change in the lithology, as the rock below the depth of 350 m changes from dense limestone to chalk.

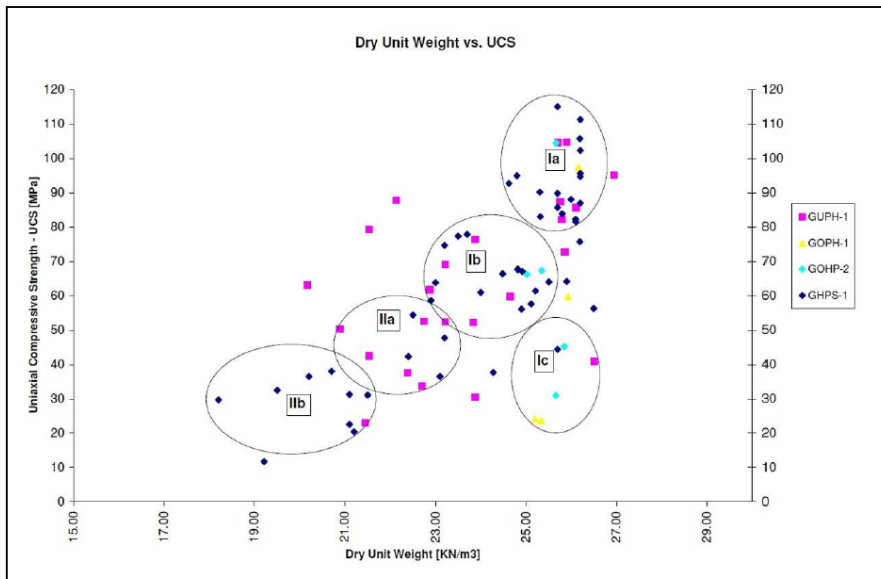

Fig. 4: Correlation between UCS vs Dry Density (intact rock)

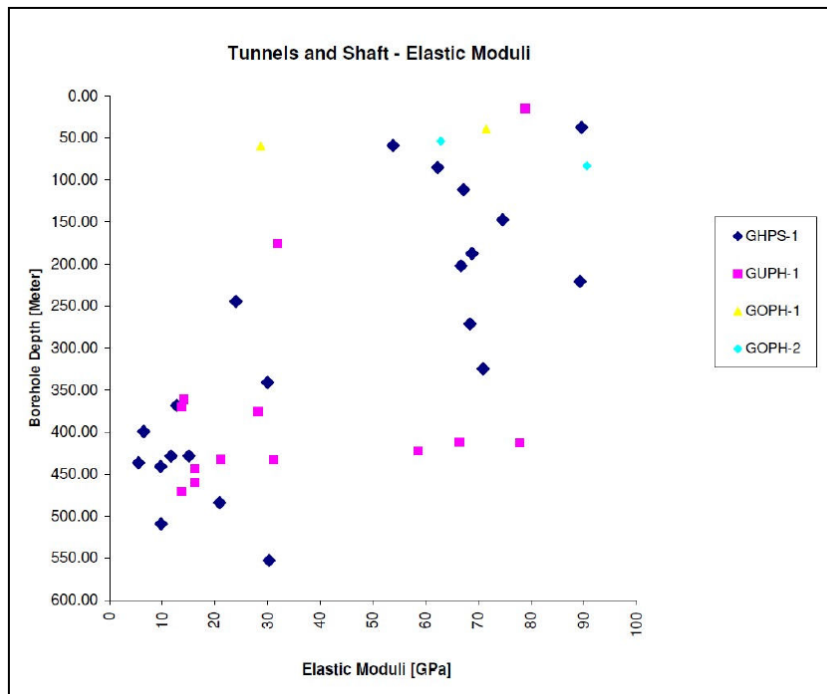

Fig. 5: Distribution of the Elastic modulus with borehole depth (intact rock)

3. The in-situ tests during the construction

The importance of deformability for the design of the steel lining raised due to the fact that the elastic modulus of the intact rock has two different ranges (one range above 50GPa and a second range below 30GPa) (Figure 5). The in-situ testing plan was executed during the construction stage in order to determine more accurately and reliably parameters for the design and to verify the preliminary design base parameters. The in-situ testing plan was based on 1) loading test ASTM D4395-04 and 2) flat jack tests ASTM-D4729-04.

The Plate Loading Test – this *in situ* test method is used for determining the rock mass modulus of deformation based on ASTM D-4395. The test method is designed to be conducted in an adit or small underground chamber. Several tests were conducted with horizontal and vertical setting in order to examine the level of isotropy. Each of the tests consisted of 5 cycles of loading and unloading up to 1.5 of the design stress. The plots of the tests are presented in Figure 7 where a symmetric deformation behavior of the rock mass has been documented.



Fig. 6: Horizontal setting of the Plate Loading Test.
(Performed by the Building and Infrastructure Testing Lab. Israel)

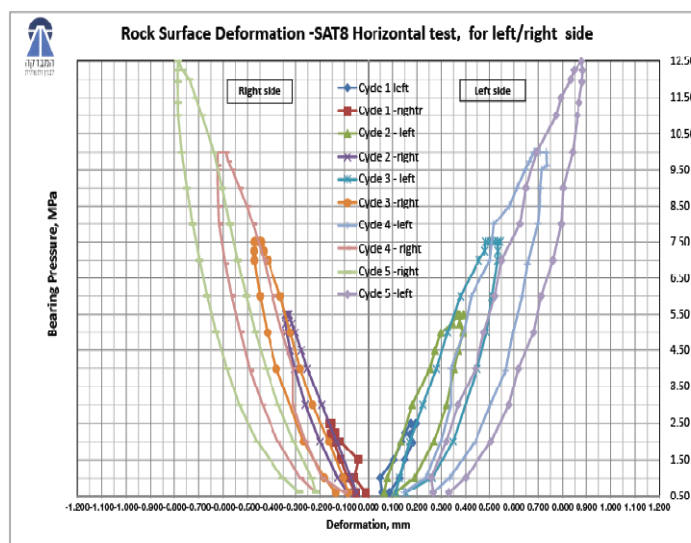

Fig. 7: Plot of the five cycles of the horizontal Plate Loading Test.

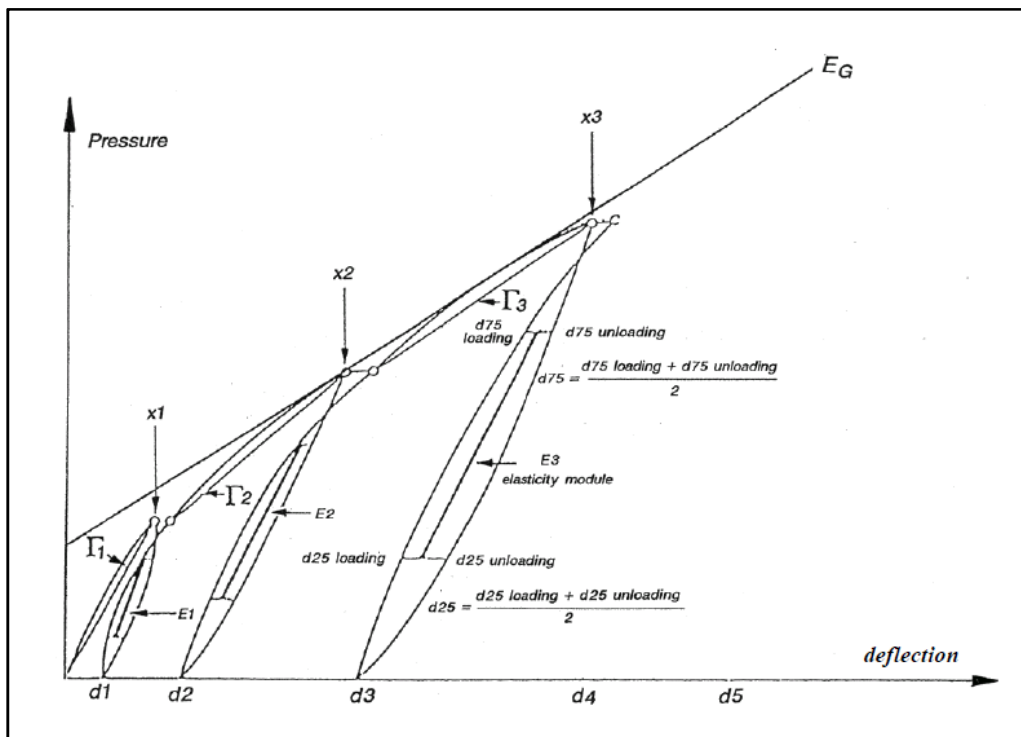

Fig. 8: Various methods for calculation of the deformation modulus.(Andre and Paradis)

Different moduli can be calculated from these curves, and there is more than one method of calculation, as demonstrated in Figure 8.

The reversible elasticity modulus E_i which corresponds to the average slope of each unloading-reloading cycle of the reversible cycles.

The calculation of these moduli is done using the Boussinesq formula (circular rigid plate loading a semi-infinite elastic isotropic material)

$$E_i = \frac{\Pi}{4} * (1 - \nu^2) * \phi * \frac{p^{75} - p^{25}}{d^{75} - d^{25}} \tag{4}$$

Where

- p^{75} : 0.75 times the maximum pressure of the cycle;
- d^{75} : average deflection for the unloading of a cycle n and the reloading of a cycle $n+1$ corresponding to p^{75} ;
- p^{25} : 0.25 times the maximum pressure of the cycle;
- d^{25} : average deflection for the unloading of a cycle n and the reloading of a cycle $n+1$ corresponding to p^{25} ;
- ν : Poisson ratio (determined through uniaxial or triaxial shear tests);
- ϕ : diameter of the plate;

The deformation modulus Γ calculated using the equation

$$\Gamma_i = \frac{\Pi}{4} * (1 - \nu^2) * \phi * \frac{p_i - p_{i-1}}{d_i - d_{i-1}} \tag{4}$$

The global deformation modulus E_G is the average of the n cycle and is also calculated using the Boussinesq formula.

The Flat Jack Test - The flatjack test measures stress at a rock surface. The modulus of deformation and the long-term deformational properties (creep) may also be evaluated. The flatjack test measures the average stress normal to the test slot. A system of three flat jacks at 45° from each other in a given plane normal to the axis of an underground opening can be used to determine the three components of the in-situ stress field acting in that plane. If the complete three-dimensional state of stress needs to be determined with flat jacks alone, a minimum of six jack tests need to be conducted in six different directions and at different locations around the periphery of the opening. Undisturbed stress levels must be determined by theoretical interpretations of these data. The stress relief is assumed to be an elastic, reversible process. In nonhomogeneous or highly fractured materials, this may not be completely true. The equations assume that the rock mass is Continuous, Homogeneous Isotropic and Linear Elastic (CHILE). Anisotropic effects may be estimated by testing in different orientations (ASTM D 4729). The suggested setting of eight flat jacks is presented in Figure 9.

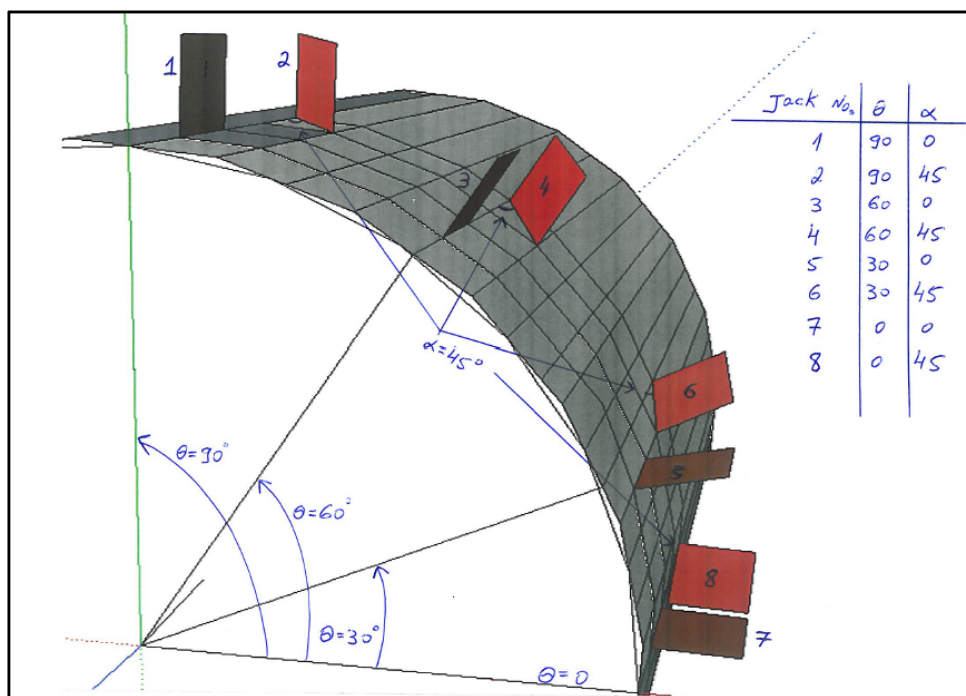

Fig 9.: The suggested setting for installation of the flat jacks around the tunnel opening

The flat jack method is both economic and simple to execute, it provides one component of the stress tensor. It must be remembered however that the stresses that are being measured in a disturbed zone. If we measure three normal stresses at three points in an underground gallery thus obtaining $\sigma_{\theta,A}$, $\sigma_{\theta,B}$, $\sigma_{\theta,C}$ as tangential stresses, then we can retrieve the magnitude of the normal stresses acting in a plane normal to the tunnel axis by inversion (e.g. (Amadei and Stephansson, 1997)).

$$\begin{Bmatrix} \sigma_{\theta,A} \\ \sigma_{\theta,B} \\ \sigma_{\theta,C} \end{Bmatrix} = \begin{Bmatrix} a_{11} & a_{12} & a_{13} \\ a_{21} & a_{22} & a_{23} \\ a_{31} & a_{32} & a_{33} \end{Bmatrix} \begin{Bmatrix} \sigma_x \\ \sigma_y \\ \tau_{xy} \end{Bmatrix} \quad (5)$$

The values of a_{ij} can be obtained by application of numerical solutions. In the simplest case of a circular tunnel as presented in figure 7 in an infinite plate in CHILE material, the kirsch solution may be employed if it may be assumed that the radius of the tunnel is much greater than the thickness of the flat jack and that the horizontal and vertical far field stresses are principal stresses. The far field horizontal and vertical stresses may be obtained by inversion as expressed in equation (6) (e.g. (Goodman, 1989);

$$\begin{Bmatrix} \sigma_{\theta,W} \\ \sigma_{\theta,R} \end{Bmatrix} = \begin{Bmatrix} -1 & 3 \\ 3 & -1 \end{Bmatrix} \begin{Bmatrix} \sigma_h \\ \sigma_v \end{Bmatrix} \quad (6)$$

Flat jack tests with a setting of six flat jacks at angle α around the opening of a circular adit close to the underground caverns is now being performed. The next stage of the interpretation will be by implementing the kirsch solution in term of the far field stress tensor.

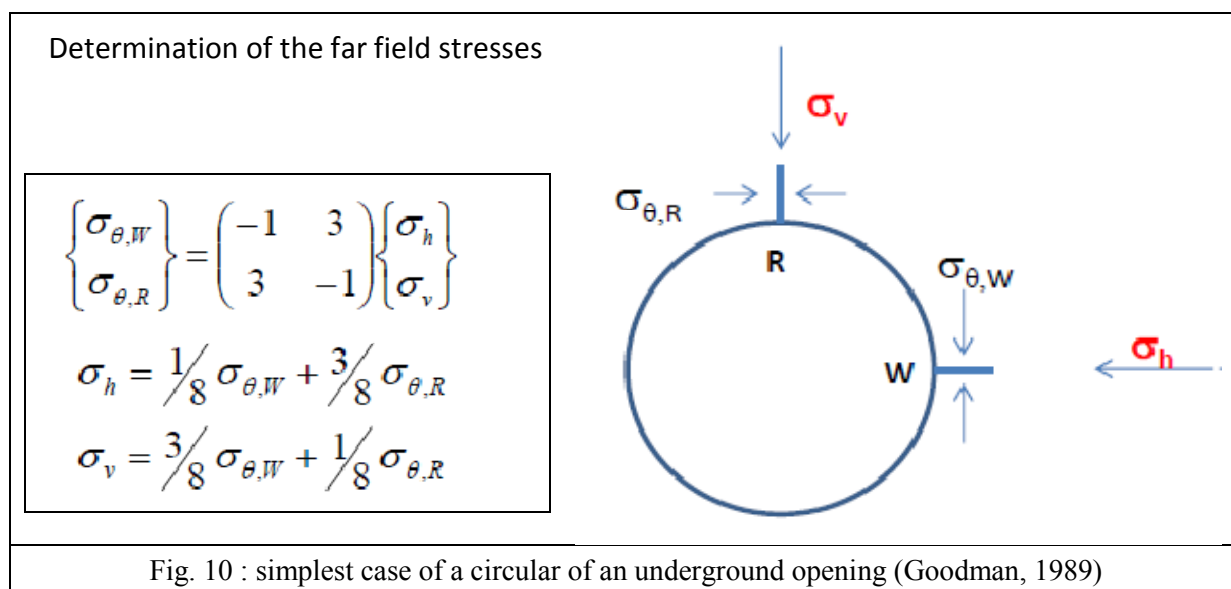

4. Conclusions

The deformability behavior of the rock mass is an essential parameter for design of the support and for an optimal design of the steel lining in hydro-electrical projects. The evaluation of the rock mass behavior has to go through different stages with definition of mile stones during the design and construction of the project in order to preserve some level of flexibility of the design parameters. The evaluation the deformability of the rock mass by combining the laboratory results of the intact rock with the rock mass structure based on the GSI method need verification of the parameters by in-situ tests. The combined in-situ test of Plate Loading Test (PLT) and Flat Jack Test (FJT) can be developed to evaluation of the far field stress condition around the underground opening.

Acknowledgements

The geotechnical work and study of the rock mass behavior is part of the design and construction of the Gilboa Pumped Storage Project where a group of companies are involved. The geotechnical work done by GEOTOPE Ltd is being founded by the Israeli companies Shikun&Binui Arison group and Electra which are the concessionaire, The French Company EDF which acts as the foreign consultants with Bernard Taquetas the owner engineer are involved in implementation of the in-situ tests and in the interpretation of the results. The In-Situ tests were performed by the Building and Infrastructure Testing Laboratory in Haifa, Israel. The geotechnical study concerning the deformability behavior of the rock mass are done in collaboration with Professor Yossef H. Hatzor, as the consultant for rock mechanics and in developing the theoretical and mathematical background for the interpretation of the in-situ tests. Nissim Tel Avivi is GEOTOPE geotechnical engineer and engineering geologist at the site and his work is essential for implementation of the in-situ tests and for the interpretation of the results.

References

- Amadei, B., Stephansson, O., 1997. Rock stress and its measurement. Chapman & Hall, London
- Andre, D., and Paradis P. (S.N.C.F). Essais de deformabilite a la plaque et au dilatometre (Deformability measurements with the plate-bearing and dilatometer tests).
- ASTM D-4729-04: In Situ Stress and Modulus of Deformation Using the Flatjack Method. American Society for Testing and Materials.
- ASTM D-4395-04: Determining the In Situ Modulus of Deformation of Rock Mass Using the Flexible Plate Loading Method. American Society for Testing and Materials.
- Hoek E, Brown E.T., 1997. Practical estimates of rock mass strength. *Int J Rock Mech Min Sci Geomech Abstr* 34:1165–1186
- Goodman, R.E., 1989. Introduction to Rock Mechanics 2nd edition.
- Hatzor, Y., and Reches, Z., 1990. Structure and Paleostresses in the Gilboa Region, Western Margins of the Central Dead-Sea Rift, *Tectonophysics*, 180(1), 87-100.
- ISRM (1979): Suggested methods for determining in situ deformability of rock. *Int. J. Rock Mech. Min. Sci. & Geomech. Abstr.*, Vol. 16, No. 3, pp. 195-214.
- Palstrom, A., and Singh, R., 2001. The deformation modulus of rock masses - comparisons between in situ tests and indirect estimates. *Tunneling and Underground Space Technology*, Vol. 16, No. 3, 2001, pp. 115 - 131
- Kirsch, 1898, Die Theorie der Elastizität und die Bedürfnisse der Festigkeitslehre. *Zeitschrift des Vereines deutscher Ingenieure*, 42, 797–807